

# Epoque, cyclical *light*.

design Stefano Papi & Saviz Yaghmai  
terzani.com



**Name**  
Epoque  
chandelier

**Materials**  
brass chains and metal  
structure plated as below



**Finishes | Code**

-  nickel plated  
OG90S E7 C8
-  black nickel plated  
OG90S E9 C8
-  bronze  
OG90S F7 C8
-  gold plated  
OG90S L6 C8

Overall height not adjustable on site  
optional custom OAH

**Body**

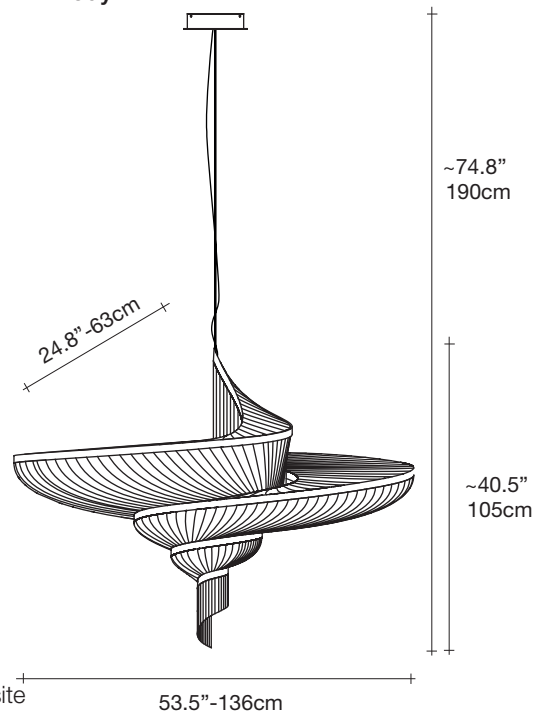

**Light source**

120V ~ 50/60Hz

-  Built in Replaceable LED Module  
20 x 2.1W 3880 lm 3000K  
or optional 3440 lm 2700K

**dimnable options**

-  1-10V  
PWM  
10-100kΩ

**Canopy**

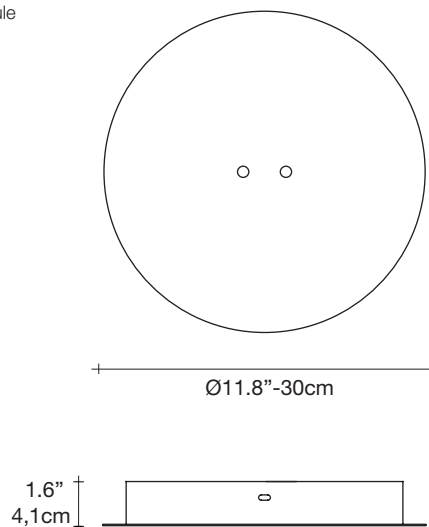

Epoque is a light sculpture designed to study chiaroscuro and volumes. The result is a modern expression of these Renaissance-era techniques in a stunning chandelier. Composed of curved, organic lines, Epoque's frame is made of flexible and durable brass metal, suspended by nickel metal chains. Two bands of metal, a central elongated section and an external band of wide arcs, allows the light to envelop a room in reflections of soft light. Epoque has attracted attention from those in the design community with discerning tastes. Epoque is available in nickel, black nickel and gold finish. Design Stefano Papi & Saviz Yaghmai.