

# I Lucci Argentati, school of *light*.

design Dodo Arslan  
terzani.com



**Name**  
I Lucci Argentati  
small linear chandelier

**Materials**  
metal



**Finishes | Code**

-  white  
ON82S M2 C8 L
-  brushed nickel plated  
ON82S H4 C8 L
-  brushed gold plated  
ON82S L9 C8 L

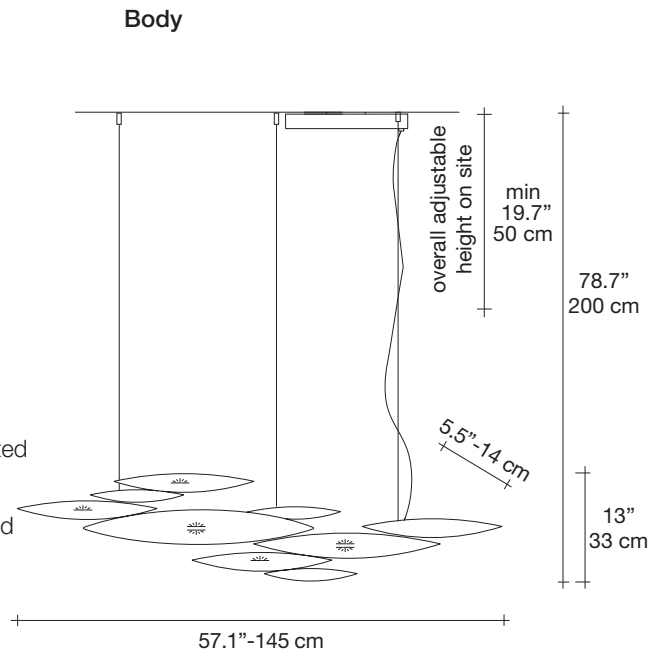

**Light source**

120V ~ 50/60Hz



Built in Replaceable LED Module  
7 x 4.5W 4632 lm CRI 90 3000K  
or optional 4200 lm 2700K

**dimnable options**



1-10V  
PWM  
10-100kΩ

**Canopy**

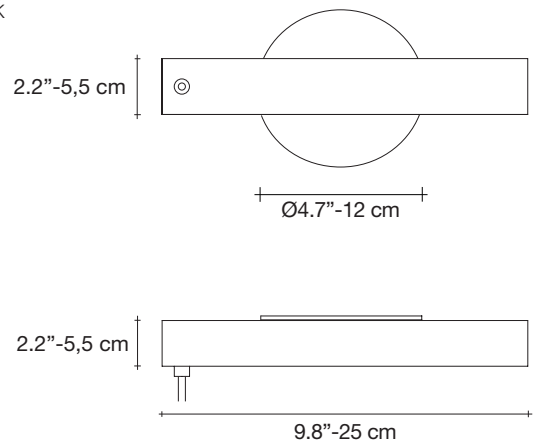

I Lucci Argentati draws from nature to create a whimsical, yet modern light. Recalling a school of fish darting through freshwater, it creates a mesmerizing luminescence. Sets of sleek elements combine to form a stunning pendant with thin incisions along the bottom creating an understated, tranquil beauty. Thanks to its modular system, I Lucci Argentati is customizable and can be combined in many different configurations: from small to extra large; as a pendant or sconce; and finished either in brushed nickel, brushed gold or white. Design Dodo Arslan. Made in Italy